

SIL 413.00

NOVEMBER 13, 2008

Page 1 of 4

TO: LeTourneau Technologies Dealers and Users

FROM: LeTourneau Technologies Product Support

SUBJECT: Hoist Cylinder Spherical Ball Lubrication

MODELS: L-950, L-1150, L-1350 Loaders

There has been some random hoist cylinder ball failures reported recently where the ball has broken in the neck.

Failure analysis has found two possible causes of these failures:

- Loose fitting plug that falls out on the inside of the tube and causes reduced lubrication and rapid liner/ball failure.
- Incorrect pre-heating of the ball causing loss of hardness. The correct heating procedure is detailed in SIL 412.00

PLUG

The hoist cylinder balls on the 950, 1150 and 1350 are greased through the ball cap/socket.

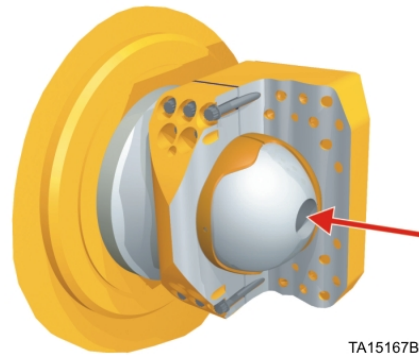

External greasing of the ball

When the ball is greased through the cap/socket there is a plug placed in the center of the ball to force the grease to go through the brass liners and prevent grease from entering the tube.

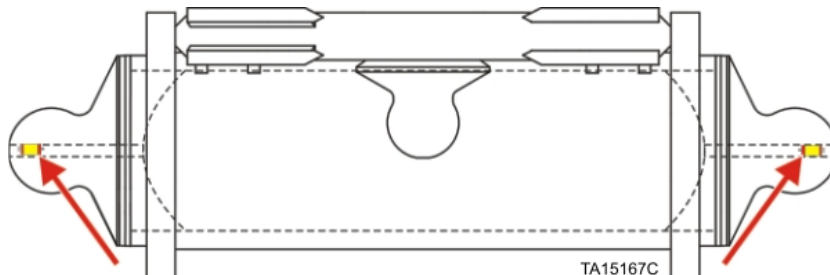

407-8325 Ball Plug locations

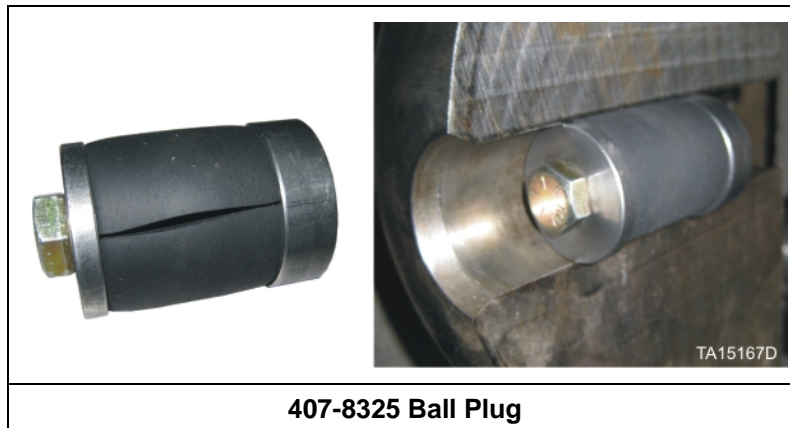

This grease plug must not move or grease will flow to the inside of the ball and tube structure – and have limited or no grease on the brass liners. This will lead to rapid wear of the brass liners and the seal groove of the socket will cut into the neck of the ball. The grooving will cause high stresses in the neck and can cause the ball to break off.

The 407-8325 plug is held in place by expansion of the rubber. We have recently found several issues with the plug:

- The hole in the ball is undersize due to the carburization process.
- The standard plug will not fit without modification
- The standard plug will in some cases not tighten properly and grease pressure will cause the plug to move through the ball and fall into the tube.

Undersize bore:

- The OD of the spacer washer and nut had to be ground down to fit into the undersize hole.
- It is also possible that the hole in the ball may have been modified by grinding so that the 407-8325 plug will fit

Not tightening:

- The rubber composition has changed and it is not as flexible as it once was and does not fully expand.
- It is possible to shorten the spacer so that the rubber will expand more fully
- It is also possible to place a washer over the spacer to tighten the rubber.

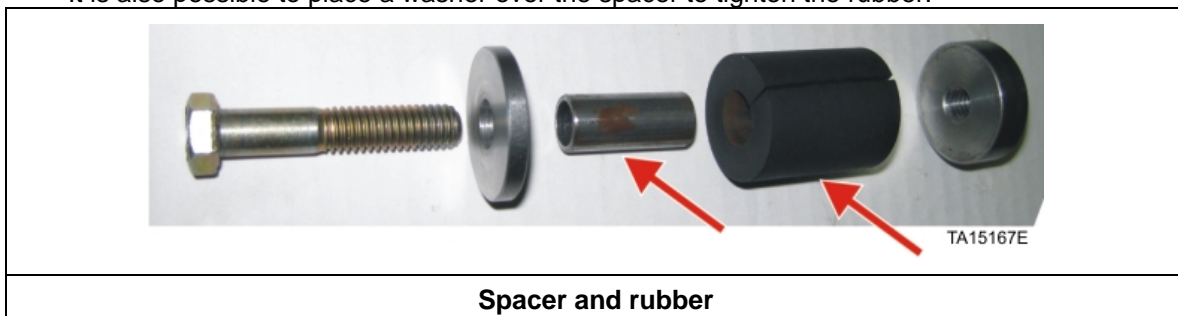

Bottom line: The plug must be tight in the bore and must not move.

NEW TYPE BALL PLUG:

A new plug is now available for this application that:

- cannot push through the ball because of a flange
- is held in place and sealed with O-ring compression.

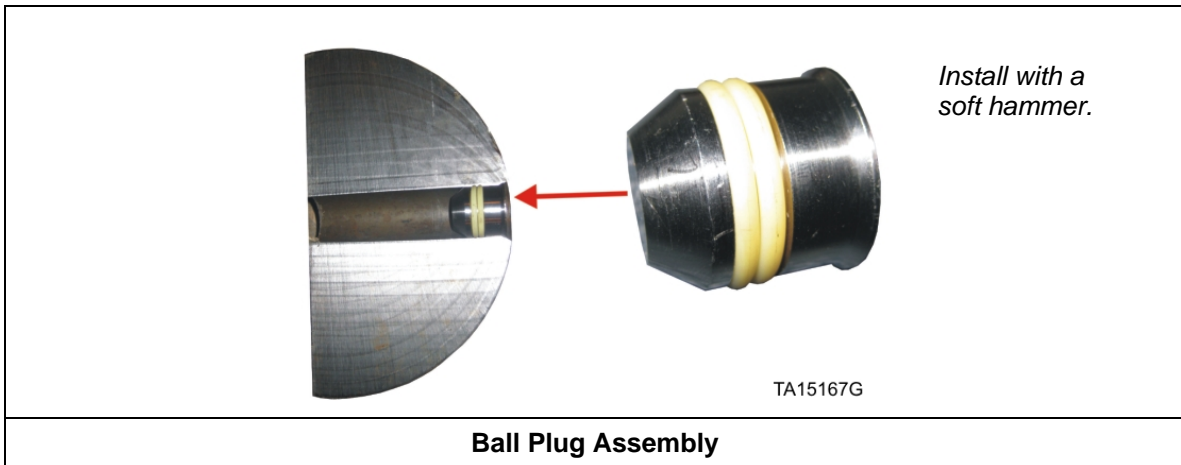
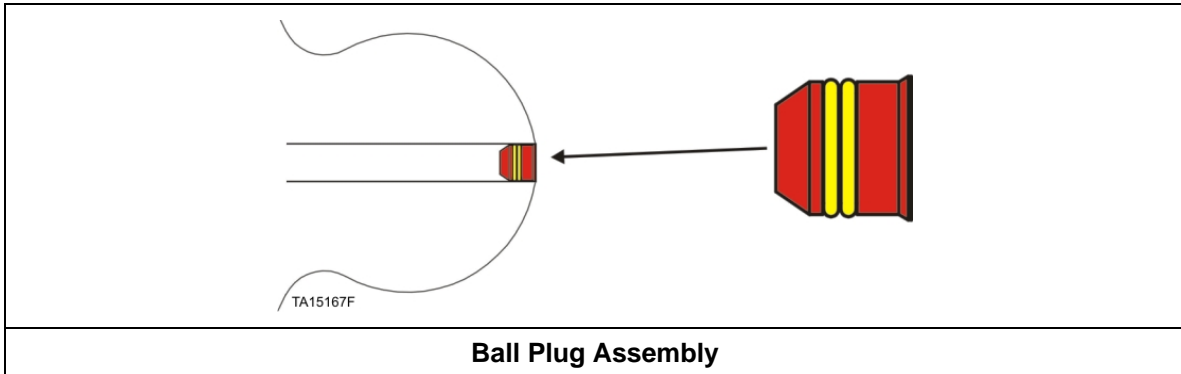

NOTE: APPLY LUBRIPLATE OR EQUAL.

2	4105004	2	O-RING .139 .984 95D PY
1	4267873	1	PLUG - BALL
ITEM	PART NO.	QTY	DESCRIPTION

TA15167H

426-7874 ASSY PLUG - BALL

Ball Plug Assembly

NOTE

The O-ring specified is a P/N 410-5004 #12 Split Flange 95 durometer urethane O-ring.

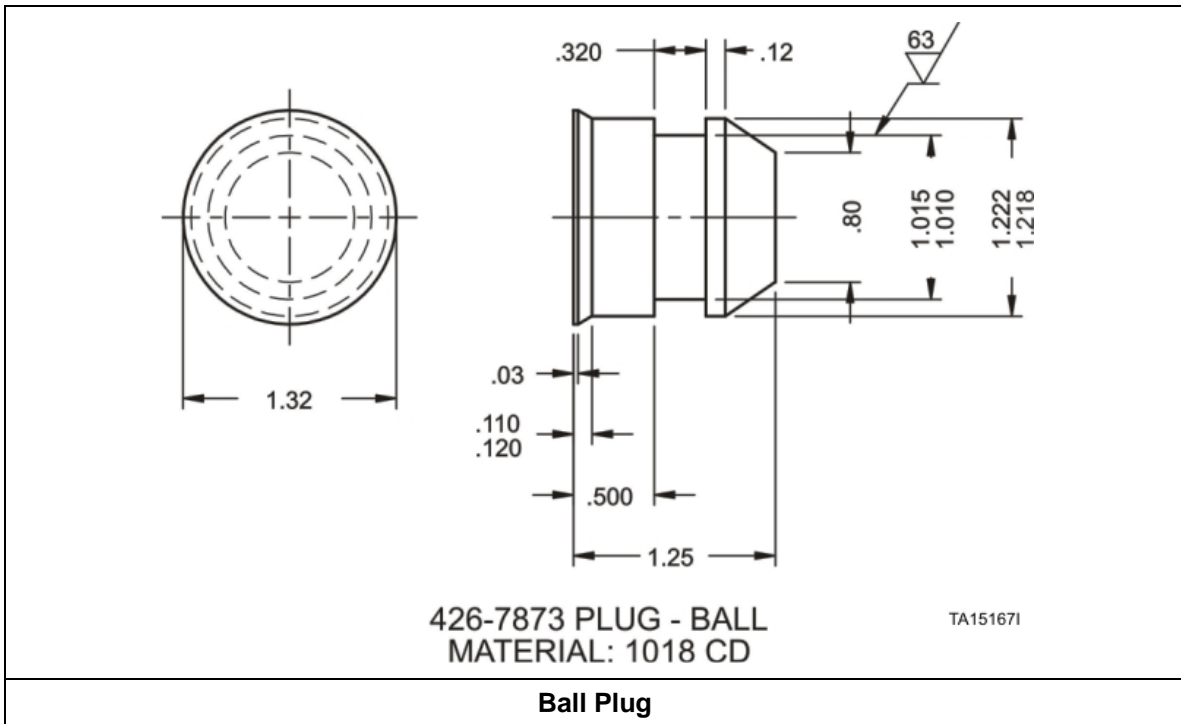

REVISION HISTORY			
Revision	Description	Created/ Modified By	Date
.00	Original Release	Randy Plants	11/13/08